



# 3D TelePresence

**Beyond the confines of flat screens for a greater sense of presence**

By Duffie White



Photo by Thomas Chan of CLSA of TelePresence Tech TPT50 system in London with telepresent person from Hong Kong

The ultimate experience of telepresence is the live interaction with people from other parts of the world as they appear before you in the same room, three-dimensionally and life-sized, with correctly aligned eye contact. However, many telepresence systems are still limited to flat screens. Furthermore, they position the cameras outside of the screen area making it impossible to have an accurate alignment of eye contact.

Due to the challenges of being able to properly replicate true perceptual dimension and eye contact, telepresence in 3D is offered by very few manufacturers. For many applications the standard flat screens of video conferencing are adequate. However, numerous customers around the world have found that 3D TelePresence has met their needs more effectively and has provided a better return on investment.



Duffie White is the founder of TelePresence Technologies, LLC of Dallas, Texas. The company has developed and patented a revolutionary technology for achieving true depth in telepresence.

TelePresence Tech has years of experience in 3D TelePresence and its systems are now in operation in Belgium, China, England, Germany, Holland, Hong Kong, India, Italy, Malaysia, Japan, Korea, Singapore, Taiwan and the United States.



Duffie appearing in 3D in London from Dallas

## History of 3D TelePresence

As a college student at the Rhode Island School of Design, I was inspired by the first public demonstration of a "Video Phone" by AT&T at the 1964 New York World's Fair. When I started my own multi-media company in 1973, I was fortunate to win contracts for AT&T, IBM, ITT, Kodak, Rockwell, General Foods, Boeing and many other corporations. By the early 1980's I had produced numerous 3D shows for my clients, but these required the audience to wear 3D glasses. To solve the problem in the mid 1980's I developed autostereoscopic (3D without glasses) displays using semi-reflective mirrors and installed these for many international meeting facilities. In 1995 my work was recognized by the British government in a quarter million dollar innovation award and a British patent was granted.

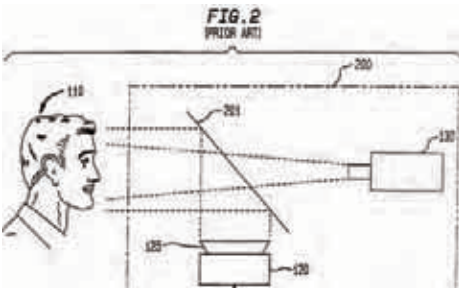

### **TelePresence with Eye Contact in Public Domain**

The technique of placing a camera behind a partially silvered mirror with an image display device positioned below to be reflected was already in the public domain (Nelson T, Smoot L, US patent 5,117,285). This teleprompter format has the disadvantage of displaying a reflected image and, therefore, the viewed image is a backwards mirror image. Examples of current video conference products in the teleprompter format can be seen at [www.teleprompters.com](http://www.teleprompters.com).

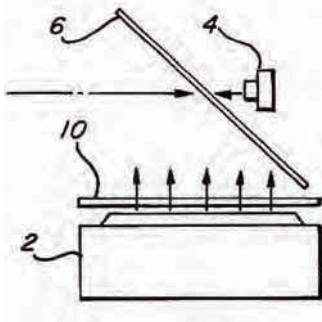

### **Variations of Teleprompter Format**

In the 1980's and early 1990's numerous companies received patents for refinements in video conferencing with eye contact. In 1995, McNelley and Machtig (now of DVE) submitted a patent application for adding a blocking film on the display monitor so that "The direct view of the display is blocked by an image blocking film applied between the beamsplitter and the display." Since then, they have received a number of patents as "Continuations in Part" to their original patent (McNelley S, Machtig J, US Patent 5,777,665).

### **Development of 3D with Eye Contact**

Since eye contact was in the public domain, I directed my development towards achieving eye contact with the life-size image of a person appearing in a three-dimensional setting. After submitting a patent application for this invention, I founded Teleportec in 1999 and my telepresence solution was featured on the Today Show in February 2000. The first transatlantic demonstration of this life-size, real-time communication in three dimensions was in June 2000 between Jeff Wacker of EDS in Dallas and myself in England (White PM, US Patent 7,136,090 and White PM, US Patent 6,783,247).



Duffie White (in England) with Jeff Wacker of EDS (in Dallas)

### **Large Scale Public Display of TelePresence in 3D**

In November of 2001, the three-dimensional visage of Arthur C. Clark was transmitted from Sri Lanka to appear on stage with Dick Brown, the Chairman of EDS, at the Comdex Exhibition in Las Vegas, NV. An audience of 5,000 viewed the author of 2001 as he was "beamed in" from the other side of the world. Clark conversed and interacted with the audience as he appeared in 3D on the stage. For several years, I managed dozens of other live events in numerous cities around the world.

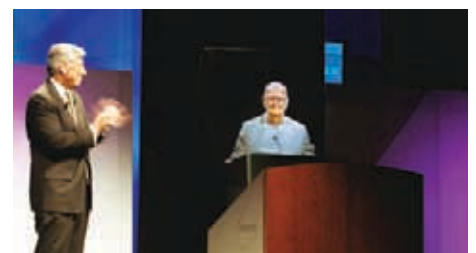

Arthur C. Clark, in Sri Lanka, appears with Dick Brown, Chairman of EDS, on stage in Las Vegas.

# Advancements of 3D TelePresence

## ***Direct View with Eye Contact in 3D***

In 2004 I founded TelePresence Technologies, LLC, (TPT) to develop a 3D telepresence solution that would overcome the disadvantages of previous teleprompter formats. In this new solution, neither the camera view nor the view of the life-size display are flipped mirror images. The direct view of the telepresent person does not suffer from aberrations caused by reflection. This format is ideal for high definition since the HD display is in direct view.



## ***Patented and Proven Technology***

Most telepresence systems display flat images of the participants. However, in 3D TelePresence, the image of the telepresent person is a physically measurable distance in front of a backdrop. This true depth relationship achieves a greater sense of presence. My invention has been granted a US Patent 7,057,637 and is protected internationally by pending patents. The TelePresence Tech products are now in their seventh generation of development. Each generation can be attributed to product design modification, field testing, and commercial applications over the course of pilot projects and large scale international implementations of the 3D TelePresence solutions over the past few years.

## ***High Quality Production***

TelePresence Tech systems are manufactured in a 114,000 sq. ft. fabrication plant in Dallas, Texas. The construction is all aluminum to deliver high strength with minimal weight. The metal components are all fabricated on advanced computer-controlled equipment based on CAD/CAM engineering with high levels of quality control. The TPT systems can be produced in quantities to meet demands for large scale international applications.



# Applications of 3D TelePresence



## **3D TelePresence on Casters**

TPT manufactures self-contained 3D TelePresence systems that can be rolled to a position at the end of a conference room table or through a single door to another meeting. These TPT systems are ideal for corporate communications, training, education, interviews, consulting and many other applications. The large plasma monitor can display one person or a small group of two or three people. The system can accommodate a data monitor for collaboration between the two sites. The TelePresence Tech systems are designed to operate with codecs from Aethra, LifeSize, Polycom, Sony and Tandberg.

## **3D TelePresence Rooms**

TelePresence Tech recently announced the development of a novel 3D TelePresence room solution. Instead of facing a wall of flat screens, the 3D TelePresence Room achieves its visual effect by hiding the display technology and creating the illusion of the transmitted people appearing to be physically in the three dimensional setting of the room. In addition, the two groups have eye contact through the alignment of the displayed people with the integrated cameras. 3D TelePresence Rooms are currently being built simultaneously in Dallas, Texas and Brussels, Belgium will be ready for demos in the United States and Europe this summer.

